



J/24 Tuning Guide

San Diego models

Thanks very much for purchasing your J/24 sails from North Sails we appreciate your business. The following tuning guide is meant to be a starting point in setting up your boat for your new sails. If you have any questions along the way we hope you will give a call or send us an e-mail. We are always ready to help you and your crew to get the most out of your new sails. Also please check our web site at www.northsailsod.com. We have posted many J/24 related articles there that may interest you and help improve your understanding of this great boat.

The tuning set up that follows is designed to be as “all purpose” as possible. Like many one designs the J/24 uses just a few sails to cover a wide range of wind and sea conditions. Set you boat up the way we have described here and you will have excellent speed in all conditions.

Section 1. With the Mast Down

- 1) Measure the length of your spreaders from the surface of the mast to the point where the shrouds touch the end of the spreaders and make sure the spreaders are as short as possible, 760 mm.
- 2) Make sure the spreaders are swept back the same amount on each side
 - a) Tie a small string tightly between the shrouds at the spreaders
 - b) Set the mast on sawhorses with track facing up and butt of the mast (with the mast butt plug in place) resting on a horse.
 - c) Using the back edge of the mast shoe as your guide check to see the string between the shrouds and aft edge of the mast shoe are parallel. (See picture #1)

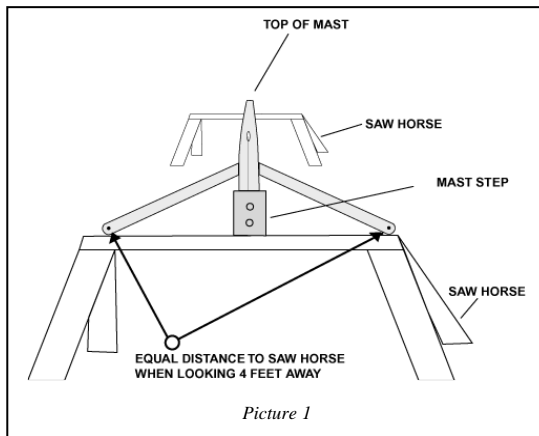

If not parallel you will need to take the spreaders off and slide the thru bar in your mast to one side or the other to compensate. If you do not have a thru bar either file down the stubby male fittings or use spreader adjusters to make the sweep the same on each side.

- 3) Now check the deflection of the spreaders. This is the distance between the taut string between the spreaders and the aft side of the mast. For the San Diego model main this should be 160-165 mm.
- 4) If your mast has not been shortened before measure down the mast from the forestay fixing point as described in the class rule 3.5.2 (7725mm down from headstay pin center). You will need this mark later to find out if your mast can be shortened. You want your mast as short as possible.
- 5) We want the headstay as long as possible. To check this, attach the headstay and hold it alongside the front of the mast and make a mark on the headstay corresponding with the mark in Rule 3.5.2 (7725mm down from headstay pin center).

Section 2. Mast Up

Step the mast and attach all shrouds very loosely (except the backstay) leaving any mast blocks out for the moment. Temporarily hold the mast butt in place on the "I" beam with a pair of vise grip pliers.

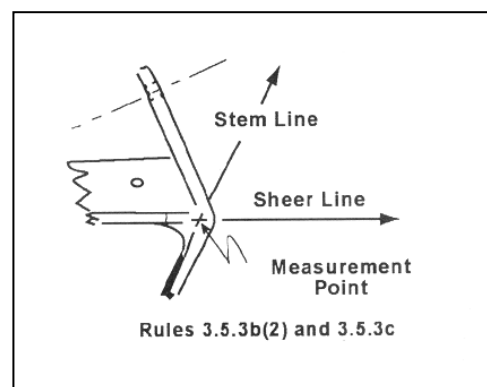

- 1) Now is the time that you want to have a class measurer with an approved jig inspect your mast to make sure it is as short as possible. The mark you previously made on the mast must be no lower than 400mm above the sheerline abreast the mast. We like to cut our mast so the lower edge of the band is 405 mm above the sheerline to ensure that our mast will always measure in. See picture #2.

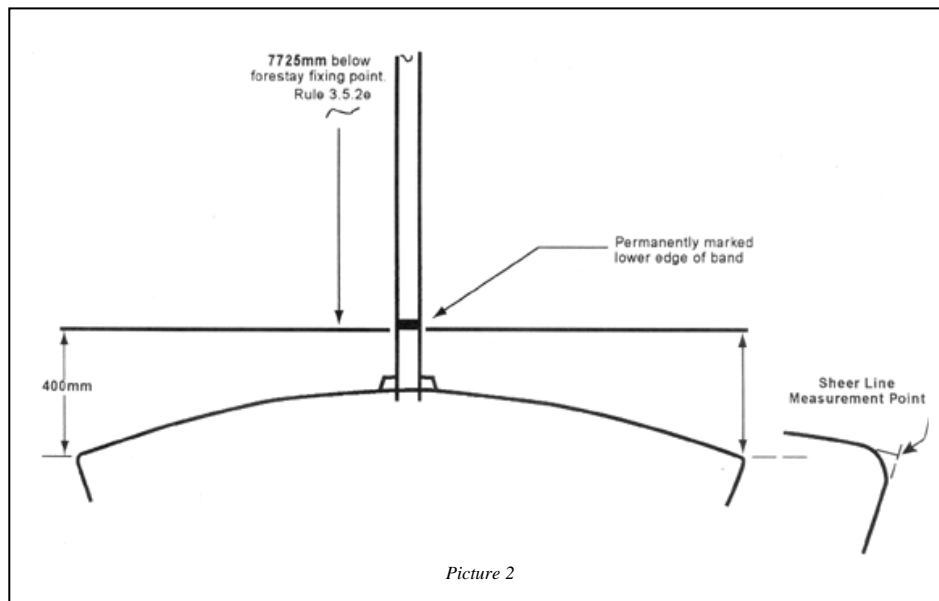

- 2) Next we need to make sure that the mast is positioned as far aft at deck level as possible. Have a friend hold the end of your tape at the stem measurement point and measure again straight to the lower edge to the mast band. We want this measurement to be as close to maximum as possible, 2925mm. Chock the mast at the deck to hold it in this position. See picture #3 for determining measurement point at stem.
- 3) The next step is to place the butt of the mast in the proper position on the "I" beam down below.

Using a friend to hold the end of the tape measure from the top of the third bolt holding the stem fitting on (inside the boat up in the bow) to the intersection of the front of the mast and the shoe the rides on the "I" beam. This measurement should be 111 5/8" (2835mm).

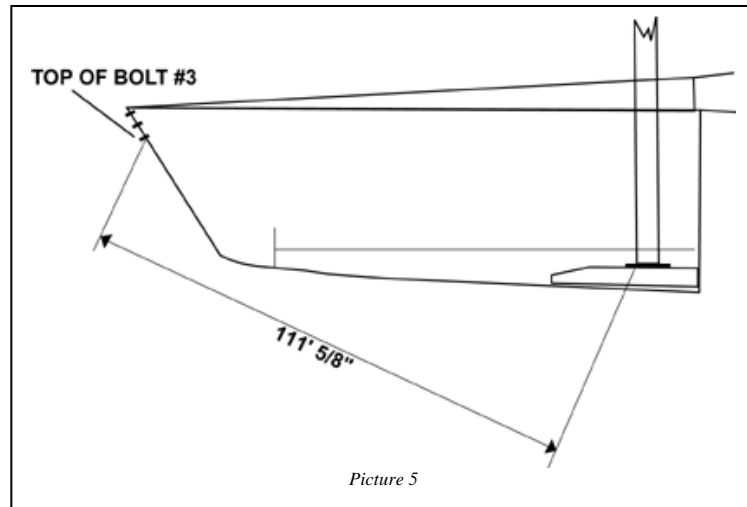

Hold the mast butt in place at this position temporarily with a pair of vise grips.

- 4) Now tighten the upper shrouds to 24 on a Loos Model B tension gauge and the lowers to 21. We get the uppers snug first and then using the genoa halyard measure down to the chainplates on both sides to be sure the mast is centered in the boat. Be sure to sight up the backside of the mast to be sure it is straight.
- 5) Now we will check to make sure the mast butt is in the right place. With the backstay disconnected measure the tension on the headstay. The tip of your gauge should be about 20-30 mm from the close side of the headstay wire. See picture #4 below.

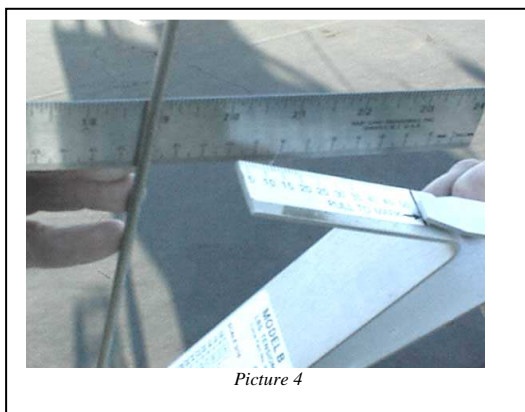

If your headstay is tighter than this you will need to move your butt aft slightly if it is looser move it forward slightly. **Be sure to check and adjust the tension on the shrouds before you recheck the headstay tension.**

At this point your mast should be set up with 25-40mm of prebend in the mast. To check this simply hold the main halyard at the gooseneck and sight up the backside of the mast. If this is not the case you will need to back and recheck your measurements.

Section 3. Tuning Chart

As we mentioned before, the J/24 has just 4 sails to cover the entire wind range the boat is raced in. For the best performance in each condition we adjust the tension on the shrouds depending on how much wind there is. As the final step in setting up your boat fill in the attached tuning chart with how many turns of the turnbuckles it take to get from one setting to another. We often adjust our shroud tensions between races (it is against class rules while racing) and it is impossible to the get accurate readings while the sails are up of the boat is in any waves at all.

San Diego J/24 Tuning Chart				
New Loos Gauge Pro Model PT2				
Wind Speed (knots)	Uppers Tension	# of full turns	Lower Tension	# of full turns
0-5	15		12	
6-9	16		13	
10-13 (BASE)	19		17	
14-17	22		19	
18+	25		26	

San Diego J/24 Tuning Chart				
Old Loos Gauge Model B				
Wind Speed (knots)	Uppers Tension	# of full turns	Lower Tension	# of full turns
0-5	18		12	
6-9	20		15	
10-13 (BASE)	24		21	
14-17	27		24	
18+	30		31	

Special note on the backstay: As you adjust the tension of your side shrouds up and down you will notice that the backstay gets tighter or looser. Each time you adjust your side shrouds be sure to adjust the two smaller backstay turnbuckles so that the blocks riding on the backstay bridles stay 150-200" below the "y" in the backstay when the tension is off. This is very important to make sure the headstay can get tight and loose enough depending on the conditions.

You are now ready to start sailing!

Sail Trim:

Follow these guidelines to set up and trim your sails.

Mainsail:

Outhaul: 0-4 knots...clew should be 15mm from black band
4+ knots...clew should be at band

Cunningham:

No cunningham until about 12 knots, then tension until wrinkles in luff are just removed.

Vang:

Upwind keep loose to 8 knots then tension to remove all slack above that. Above 15 knots tension very hard so boom does not rise at all when the mainsheet is eased. Downwind tension so top batten is parallel to boom.

Traveler:

Keep all the way up on weather side until crew is all sitting out on weather side with legs out. As soon as crew is on weather rail with legs over, drop down 50mm. Then drop it down as far as the middle of the track to keep the boat flat. If you have to drop below middle to keep boat flat put on some backstay and keep traveler in the middle. Play traveler in puffs to keep boat flat as wind builds. We do not like to sail with traveler below $\frac{3}{4}$'s of the way down.

Backstay:

Use to control fullness on main and genoa. Leave loose until about 8 knots. Slowly tighten as breeze builds to depower boat. At it's tightest, it will be all the way down to the top of the pushpit. A small adjustment (25-50mm) can have a big effect here. Be sure to adjust the backstay turnbuckles when adjusting the side shrouds.

Mainsheet:

Tension mainsheet so top batten is parallel to the boom and the top telltale is flying 50-60% of the time up to 10 knots of wind. Above that the top telltale should be flying all the time because now the top of the main will be flatter.

Mainsail Setting Chart

<i>Wind Speed</i>	<i>Traveler</i>	<i>Backstay</i>	<i>Top Batten Angle</i>	<i>Outhaul</i>
0-6 knots	All way up	None	Closed 3 degrees	In 15mm
7-12	Down 50-70mm	¼ on	Closed 3 degrees to parallel	Max. tight
12-18	Middle	½ to ¾ on	Parallel to open 3 degrees	Max. tight
18+	Below CL 50-70mm	Max on	Open 3-6 degrees	Max. tight

Genoa set up:

With the genoa there are three major things we are concerned with, having the lead in the proper position, having the genoa halyard set right and getting the sheet tension right.

Halyard Tension:

We want the halyard set so the luff of the genoa has just a hint of wrinkles in it. The reason is that we have found that it is better to have the halyard too loose rather than too tight. In light air we want to be sure that the luff is nice and loose. As the wind builds, we tension the halyard enough that the cloth along the luff of the genoa is smooth.

It is important to have a mark for your genoa halyard near the cleats or stopper that keep it in position. We mark off 15mm increments to make it easier to duplicate fast settings.

Lead Position:

Note that it is important that you have drilled out an extra set of holes between each of the factory-drilled holes in your genoa track. The standard spacing is too far apart to be workable.

Having the lead in the correct position is critical for good speed. In moderate breeze (4-8 knots), trim the sail in and position the lead car so that the sail touches the spreader and the chainplates or turnbuckles at exactly the same time. Mark this position. This will be your **neutral** point for your jib lead.

Sheet Tension:

We check the sheet tension by judging how many inches the sail is trimmed away from the end of the spreader. Generally we never trim the sail tighter than 1" from the end of the spreader.

Genoa Setting Chart

Condition	Lead	Halyard	Sheet
0-6 flat	1 aft of neutral	Wrinkles	3-4" off spreader
0-6 choppy	On Neutral	Wrinkles	3-6" off spreader
7-13 flat	On Neutral	Just Smooth	2-3" off spreader
7-13 choppy	1-2 holes fwd.	Wrinkles	2-4" off spreader
14-18 choppy	1-2 holes fwd	Smooth	4-6" off spreader
18+	On neutral	Tight	6-8" off spreader

As the above chart shows it is important to change your settings depending on the condition. Be aware that as the wind builds and dies you will need to be constantly adjusting the tension on the genoa sheet.

Class Jib Trim:

For fine-tuning the lead position, drill two extra holes between each set of factory holes in the jib track. Start with the jib lead block positioned at the chainplates and fine tune the lead position from there.

Unlike the genoa the luff of the jib should always be smooth. Be careful, you can in moderately heavy air get the luff too tight. The luff of the sail should break evenly up and down. If the sail breaks high first move the lead forward, low first move the lead back. Check this carefully and make a mark on the deck in the correct spot.

Sheet tension is critical. We like to adjust the tension on the jib sheet to balance out the helm of the boat. If the boat has a bit of weather helm trim the jib slightly to pull the bow down. If the boat has leeward helm ease the jib slightly. Keep in mind that you only need to change the tension on the sheet very slightly (1/2" increments) to have a real effect on the trim of a high aspect sail like the jib.

Spinnaker Trim:

The spinnaker should be at full hoist at all times. The general rule of trim is to allow 2-4" (50-102 mm) of curl in the luff of the sail. The outboard end of the pole should be even with the free floating clew and the pole should remain perpendicular to the apparent wind. Use the upper pole ring for most conditions. If you are going slow try raising the pole a couple of inches.

Downwind—light air: Concentrate on good communication between helmsman and spinnaker trimmer. The goal is to sail as low as possible while still maintaining good pressure in the spinnaker (measured by tension on the sheet). Try not to sail too high which translates into longer distances, but do not sail too low at a slow pace. Be careful not to pull the pole too far aft which flattens the spinnaker.

Downwind—heavy air: Be careful not to square the pole back too far as this makes it easier for the spinnaker to roll out to weather. Do not let the clew of the spinnaker go past the headstay. Keep most of the crew hiked on the leeward side in order to sail low and not risk rolling to weather.

Downwind tips:

1. Pole height is important and changes in increments of 1" (25 mm) have a big effect on the spinnaker. The break the sail should curl evenly from top to bottom . If the spinnaker breaks high, the pole is too low and should be raised. If the break is low, the pole is too high and should be lowered.
2. Whether or not you use tweakers (or twings), an efficient foreguy system is crucial. Every up and down, or back and forth motion of the pole (and hence the spinnaker) is wasted energy; that energy will not be pulling the boat forward.
3. An efficient system for launching and retrieving the spinnaker is a must. We recommend a deep cockpit launching bag. *Call us if you would like one made for your J/24.*

In conclusion:

- Always sail the boat as flat as possible except for very light air
- Sail as close to max weight limit of 400 kgs as possible.
- Do not be afraid to change settings if you are slow.
- Keep a tuning chart and use it.
- Have open positive communication on board.
- Sail fast and have fun!

APPENDIX A - J/24 SAIL CARE

Your North Sails are constructed out of the best materials on the market today. We make sure of this by testing every roll of cloth we use. Through proper care and maintenance your sails will give you the performance you have come to expect from a North Sail

The most important factor for a long life for your sails is to watch them for signs of wear and tear in high load and chafe areas. Be sure to wash the sails off with fresh water and dry the sails thoroughly before storing. A dry, mild climate is best. Excessive heat can cause problems with the sails due to the possibility of shrinkage. It is best to roll the mainsail, genoa, and jib.

Mainsail

When hoisting and lowering the sail try to minimize the amount of creasing or wrinkling of the sail. Every time the sail gains a crease the cloth breaks down that much faster. Always have someone contain the leech and luff during these procedures.

The battens can be left in the sail without any problems. Be sure to roll the sail down the leech so that the battens will not twist. This could cause damage to the battens.

Genoa

With today's Mylars becoming softer this process has become more difficult. When folding, creasing can develop from folds and accelerate the breaking down of the Mylar. The worse case scenario is for the sail to be rolled and then folded.

Jib

When rolling the jib keep the battens perpendicular to the leech. Pay special attention to the battens and batten pockets for wear and tear. Since this sail is manufactured from yarn tempered Dacron, problems can arise due to mishandling.

Spinnaker

The spinnaker is fairly straight forward. Be sure to repair all tears and pulled stitches. Folding the sail when storing is best.

CONTACT NORTH SAILS

For tuning information and complete details on how to setup your J/24 sails contact the North J/24 experts at:

NORTH SAILS SYDNEY

Julian Plante

Ph 02 9997 5966

julian@au.northsails.com

Good Sailing!